

PERMITS

CITY OF MELVILLE
PUBLIC WORKS & PLANNING SERVICES
BOX 1240, 100 BRUNSWICK STREET
MELVILLE, SK S0A 2P0



Office Hours:
8:00am – 4:00pm
Monday — Friday

A Development and Building Permit are required for:

- ⇒ Exterior stairs that are four or more risers high
- ⇒ Exterior landings that are greater than 2.25 m² (or 25 sq ft.) in area, and/or landings that are 600mm (24”) above grade level
- ⇒ Decks that are more than 200mm (8”) above grade level
- ⇒ Roof enclosures over an existing deck

Telephone:

306-728-6865

Fax:

306-728-5832

Email:

publicworks@melville.ca

Social Media:

www.melville.ca

www.facebook.com

This pamphlet has no legal status and cannot be used as an official interpretation of the various codes and regulations currently in effect. The City of Melville accepts no responsibility to persons relying solely on this information.

Deck Checklist



Property Line

Sketch house footprint and deck location with distances to Property Lines. Show overall dimensions of the deck.

Please complete all information.

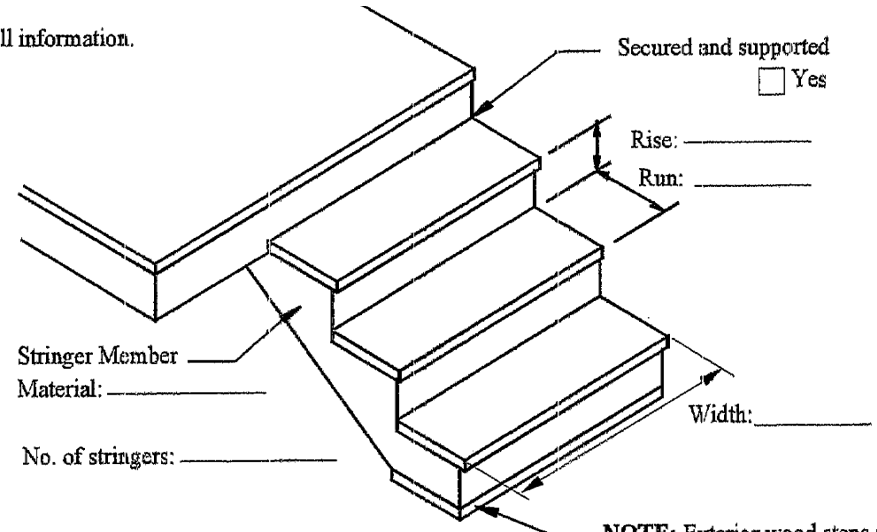

NOTE: Exterior wood steps shall not be in direct contact with the ground unless suitably treated with a wood preservative.

NOTE: Handrail required when more than 3 risers.

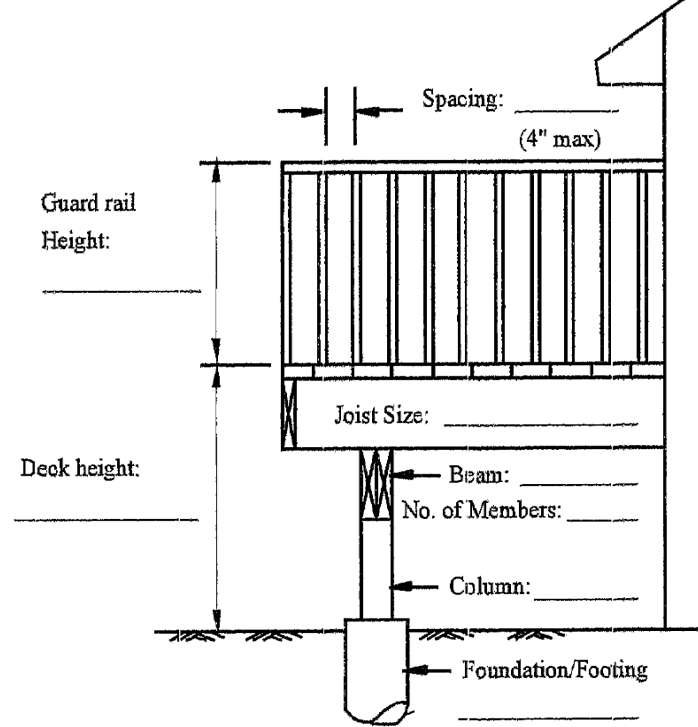

NOTE: Guard rail required when deck height is > 24" (600 mm) above finished grade.

